

Canopy Wiring Guide

SMM SteelTop® Canopy

Note: This is the wiring guide supplied by the manufacturer. All wiring should be completed by a trained auto electrician. Please refer to Ford documentation to locate the wires in the vehicle as required.

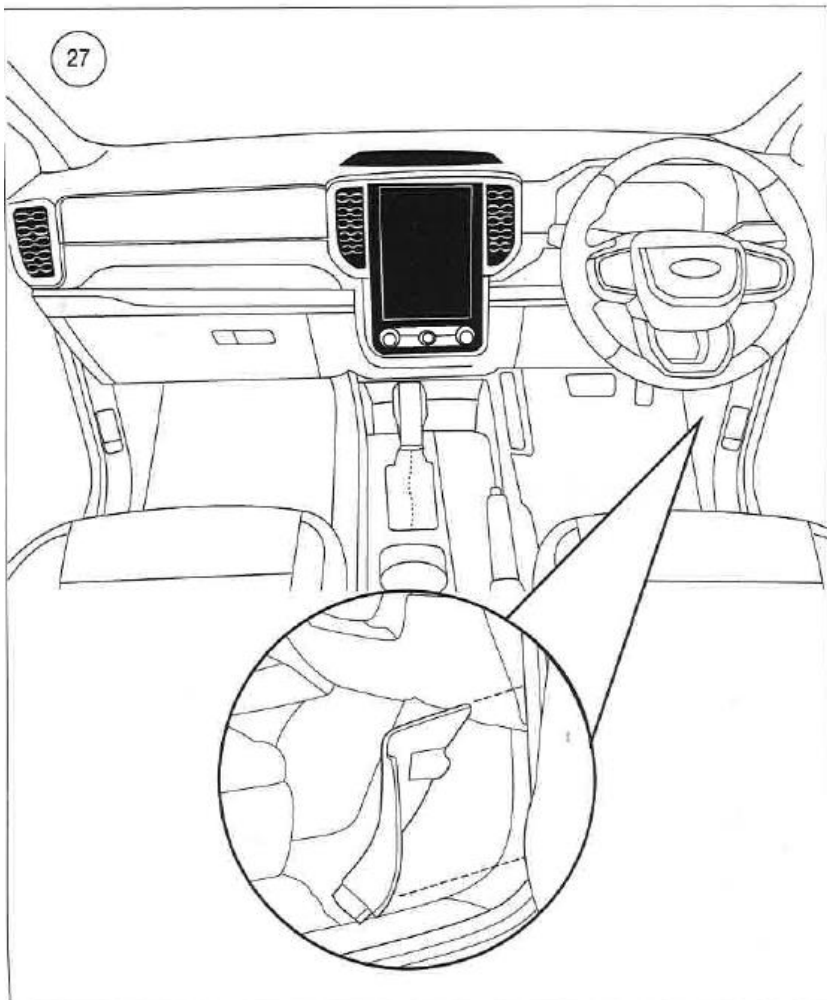

Take off the Wiring Cover at the driver side in order to check the wiring position.

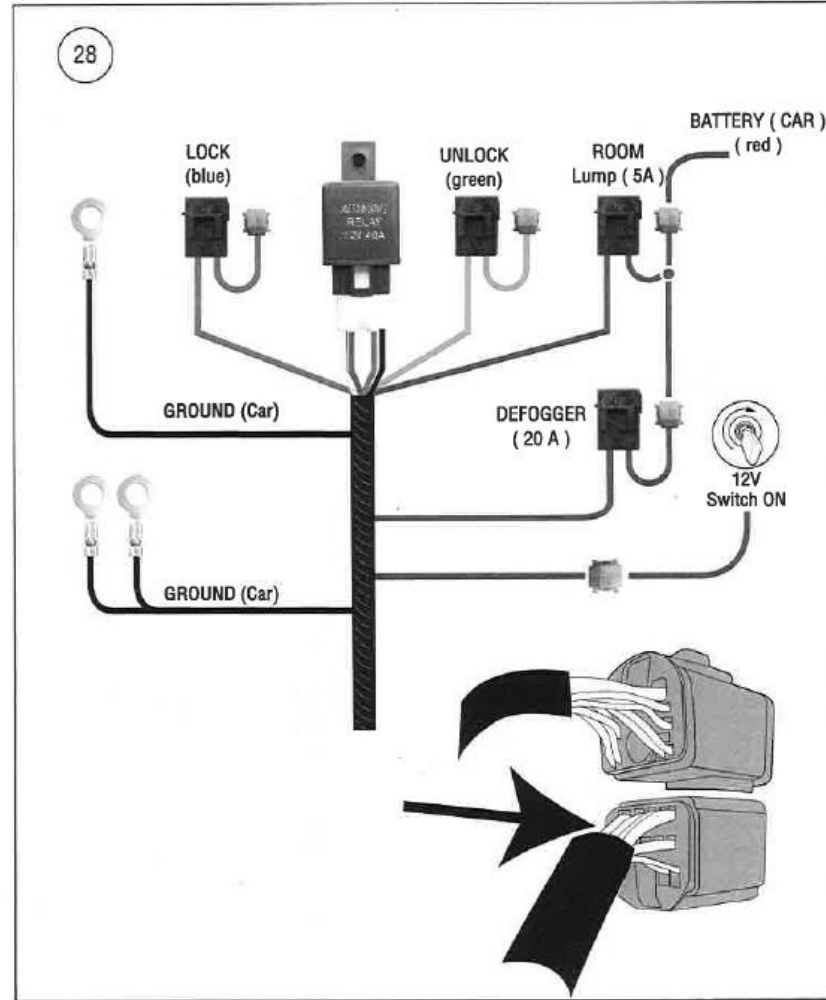

Harness Central Lock No.38

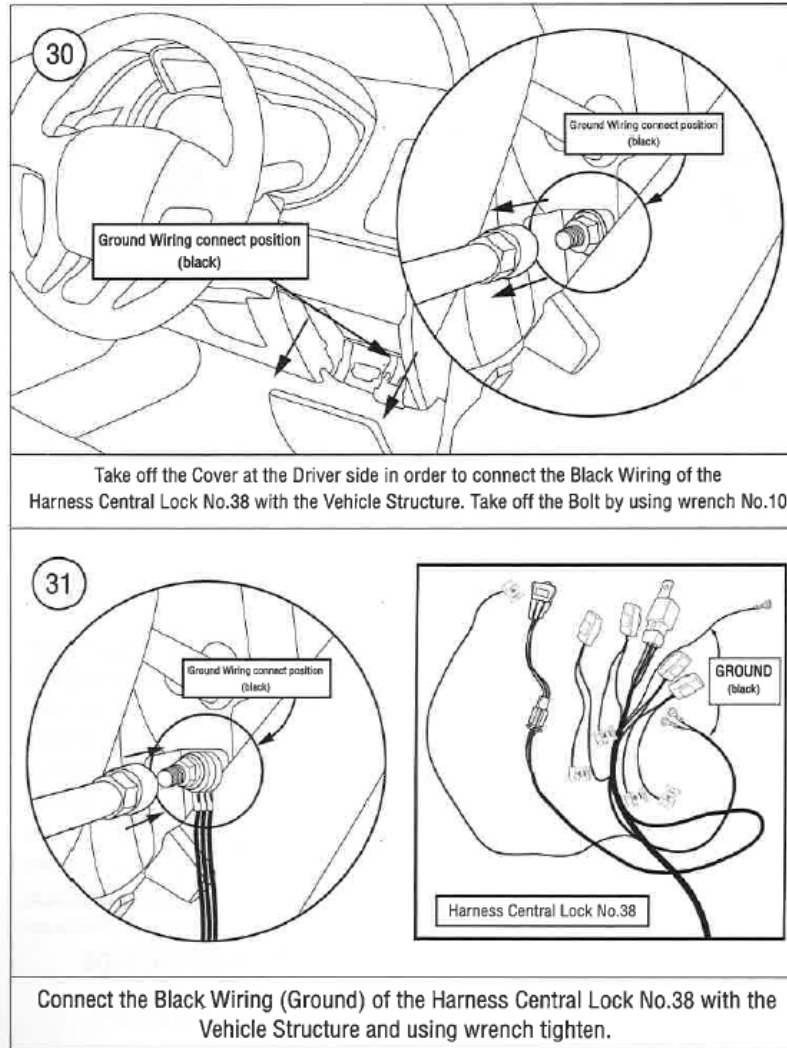
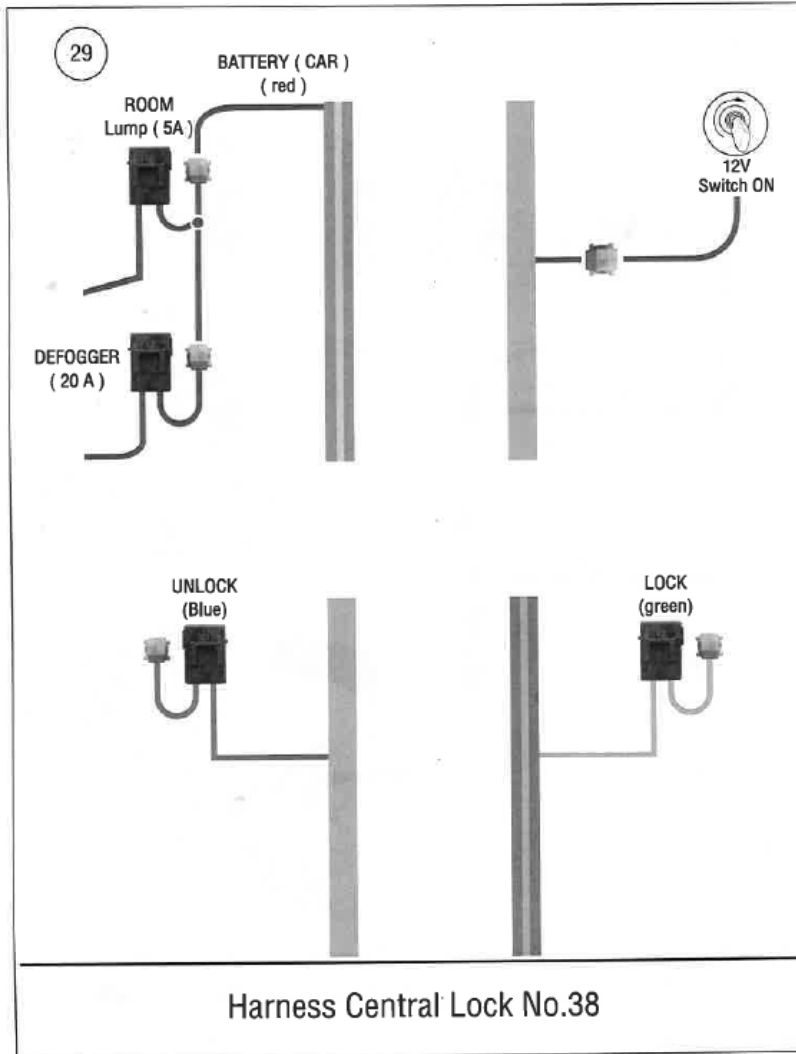

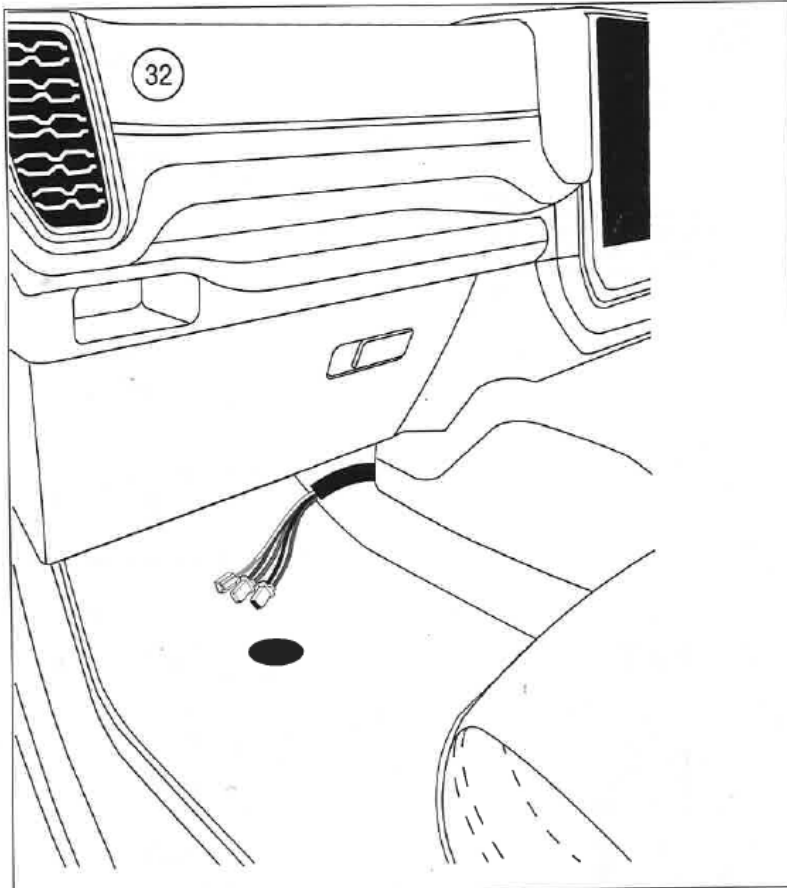

Running canopy wiring via vehicle wiring hole/pipe along under the chassis.

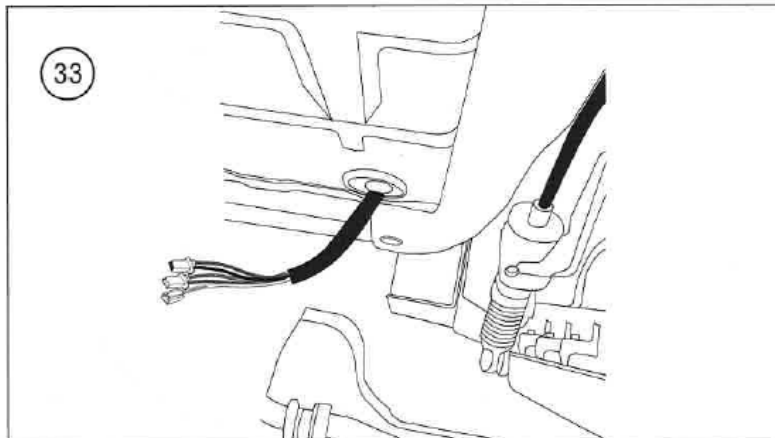

Run the wiring through the hole of the vehicle floor and seal to protect water leaking problem.

34 The Step of wiring running diagram

Point 1 Wiring running from driver side through passenger side.

Point 2 Running canopy wiring via vehicle wiring hole/pipe along under the chassis.

Point 3 Wiring that run under vehicle along the chassis.

Point 4 Wiring that run via chassis at the fender area.

Point 5 Wiring that running up the rear light in order to connect with the other wiring set.

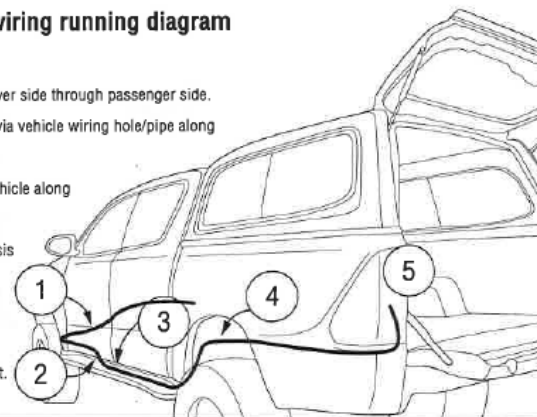

The Step of wiring running diagram for the Harness Central Lock No.38

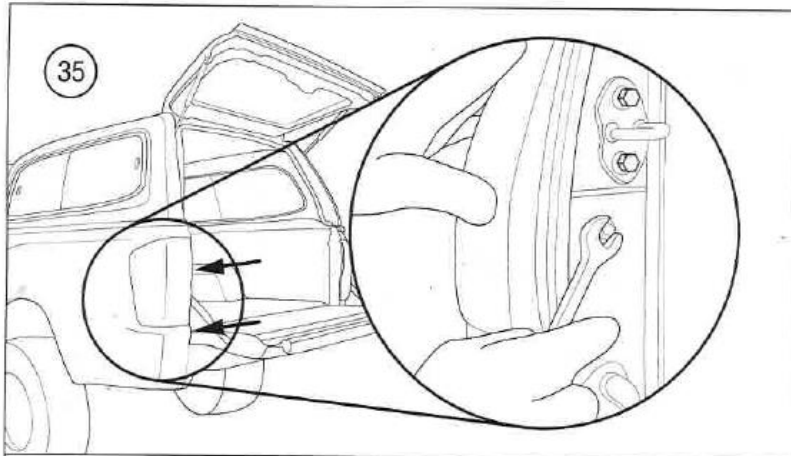

Take off the Rear Light by using wrench No.10

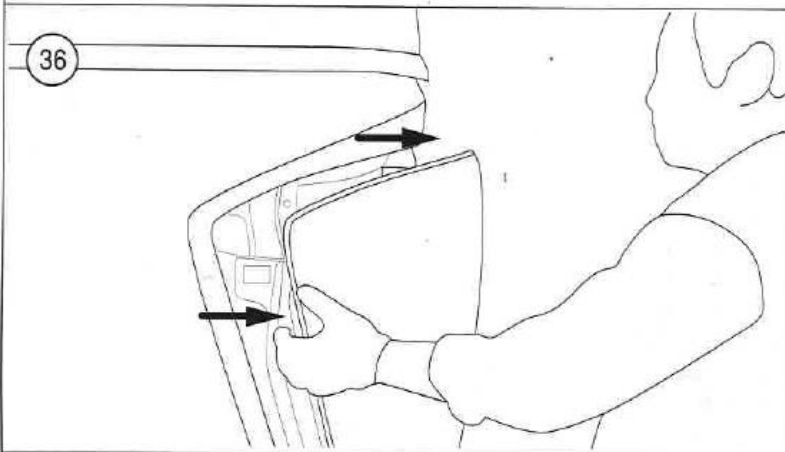

Take off the Rear Light vehicle.

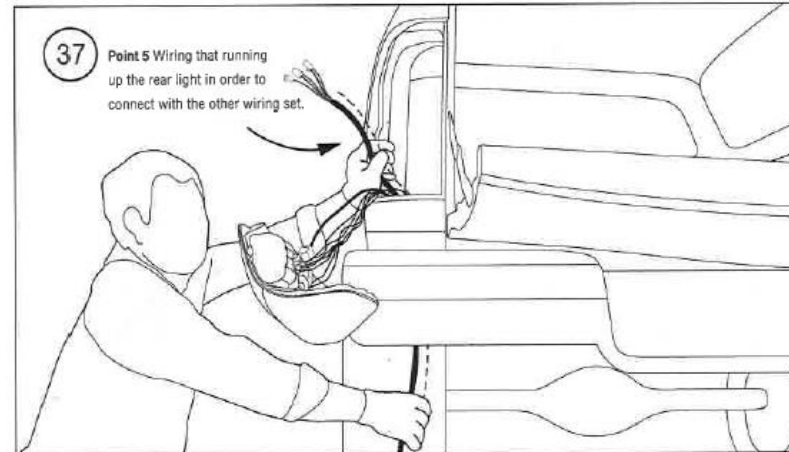

37 Point 5 Wiring that running up the rear light in order to connect with the other wiring set.

Running the Harness Central Lock No.38 up to the vehicle rear light in order to connects with the Harness Central Lock No.32.

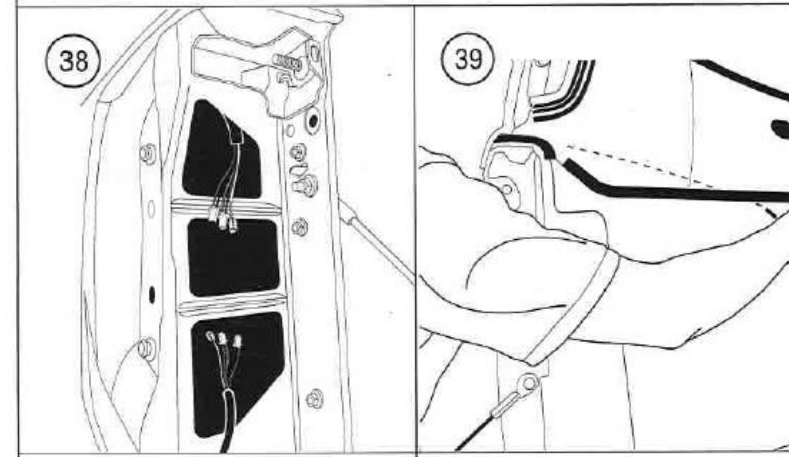

38

39

Run the rod along the vehicle edge till the Rear vehicle light.

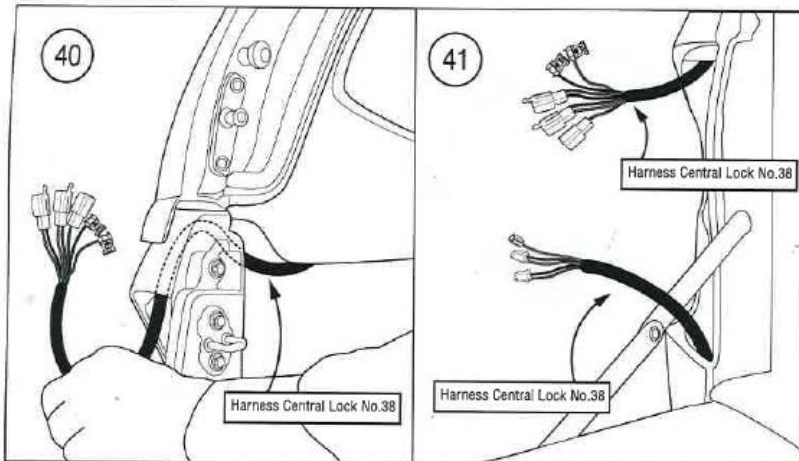

40

Harness Central Lock No.38

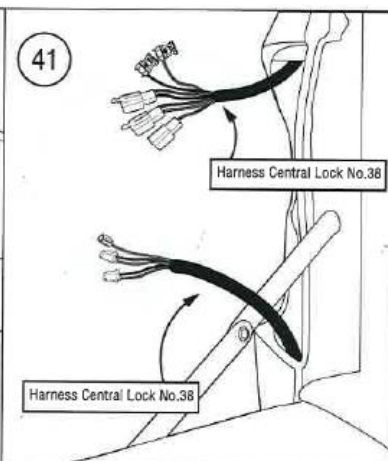

41

Harness Central Lock No.38

Harness Central Lock No.38

Run the Harness Central Lock No.38 along the vehicle tub channel out of the Rear Light Socket.

The Harness Central Lock No.38 wiring vehicle position and the Harness Central Lock No.38 wiring set.

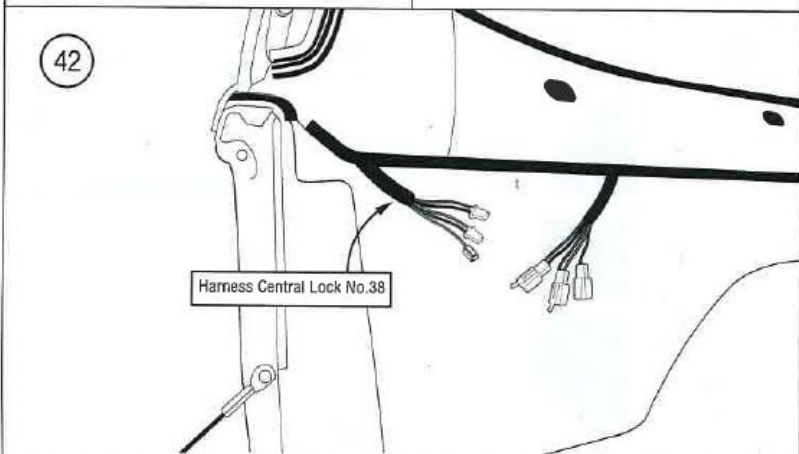

42

Harness Central Lock No.38

Re-assembly Harness Central Lock No.38 of all positions back to the spots.

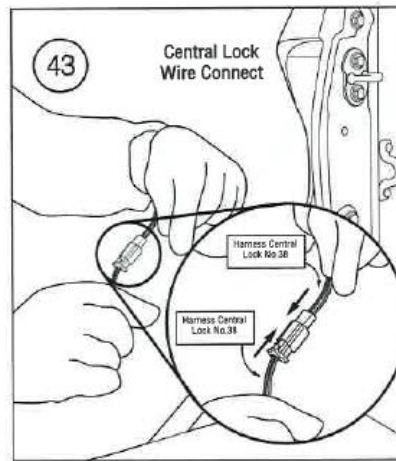

43

Central Lock Wire Connect

Harness Central Lock No.38

Harness Central Lock No.38

The Process of Connecting Central Lock (BL,DG) Wiring of the Harness Central lock NO.38 With the Central Lock (BL,DG) Wiring of the Harness Central lock NO.38

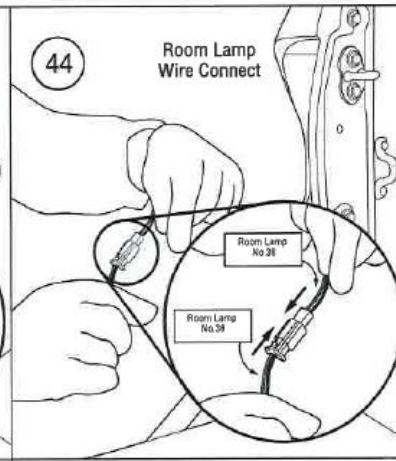

44

Room Lamp Wire Connect

Room Lamp No.38

Room Lamp No.38

The Process of Connecting the Room Lamp (RD,BK) Wiring Harness Central lock NO.38 With the Room Lamp (RD,BK) Wiring Harness Central lock NO.38

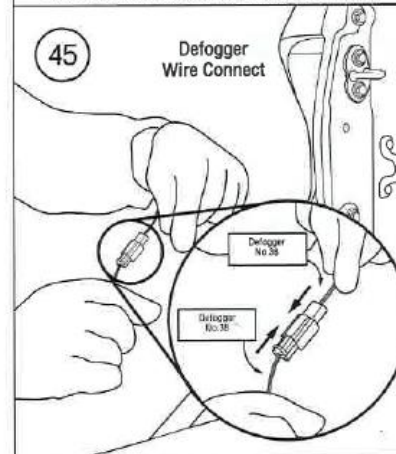

45

Defogger Wire Connect

Defogger No.38

Defogger No.38

The step of connecting the Defogger (YL/RD) wiring of the Harness Central Lock No.38 with the Defogger (YL/RD) wiring of the Harness Central Lock No.38.

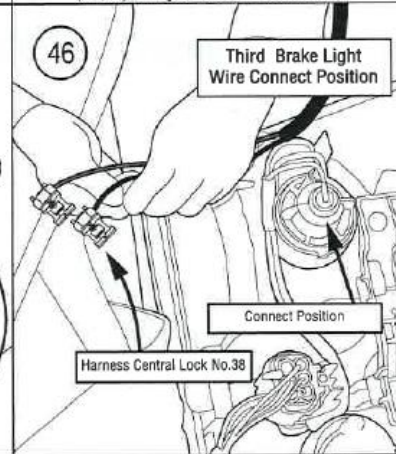

46

Third Brake Light Wire Connect Position

Connect Position

Harness Central Lock No.38

The position of connecting the Red and Black Wiring of the Third Brake Light (RD,BK) circuit of the Harness Central Lock No.38 with the vehicle rear light.

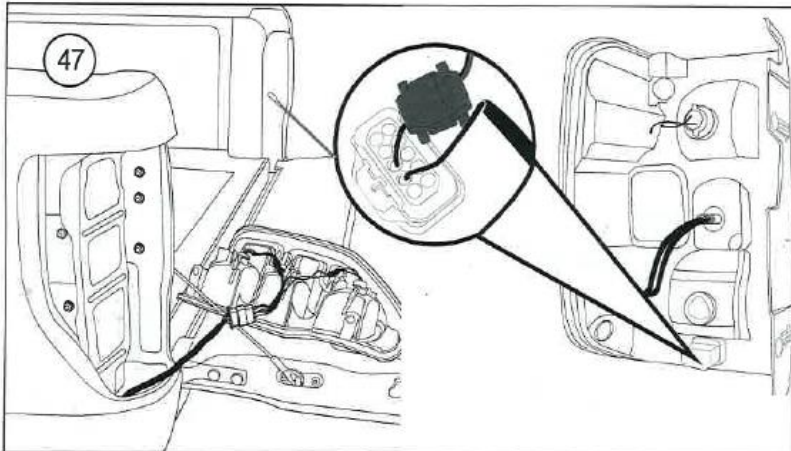

Connect the Red wiring, third Brake Light (RD) of the Harness Central Lock No.38 with the Black Brake Light Wiring on the Left Side of the Rear vehicle light.

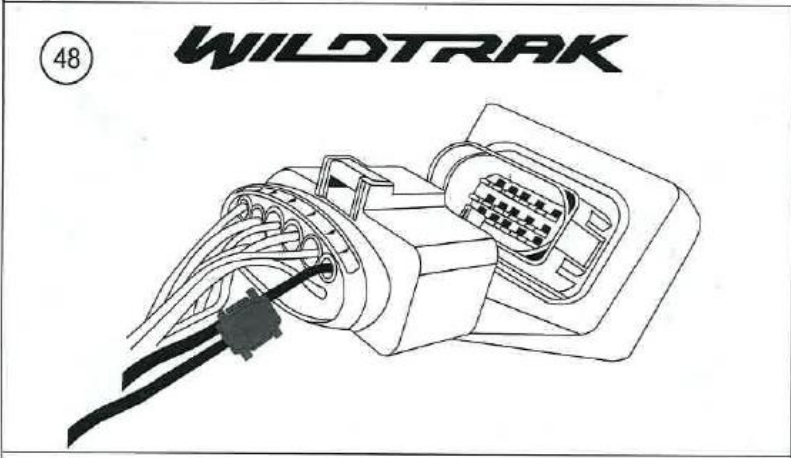

Connect Position Wiring Brake Light (Wildtrak)

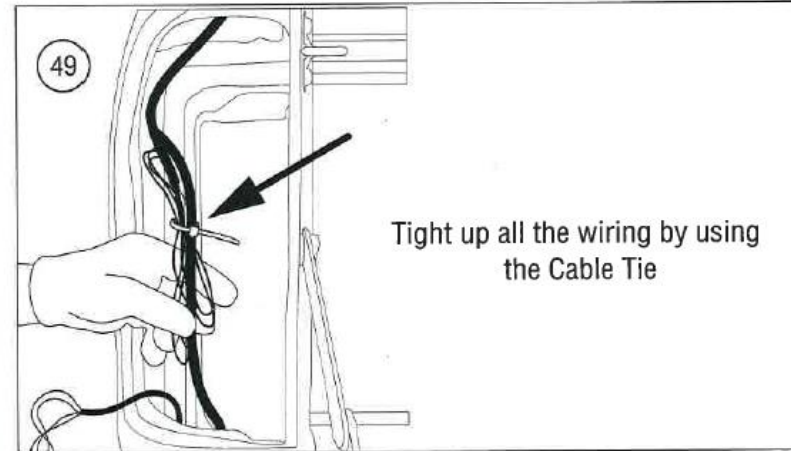

Tight up all the wiring by using the Cable Tie

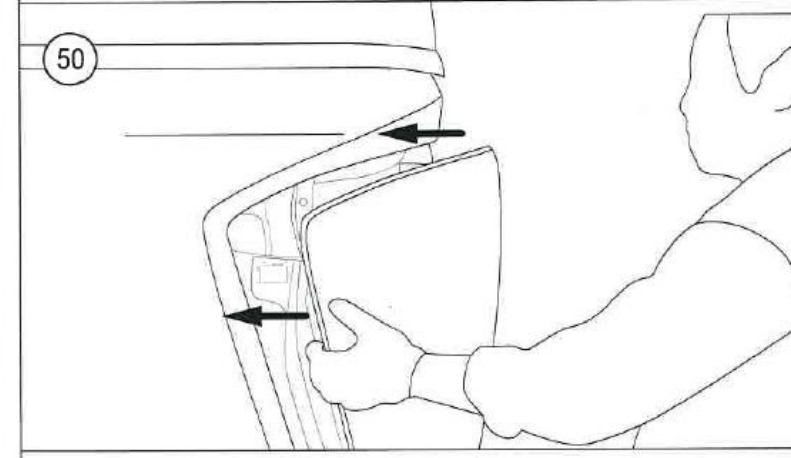

Take off the Rear Light vehicle.

51

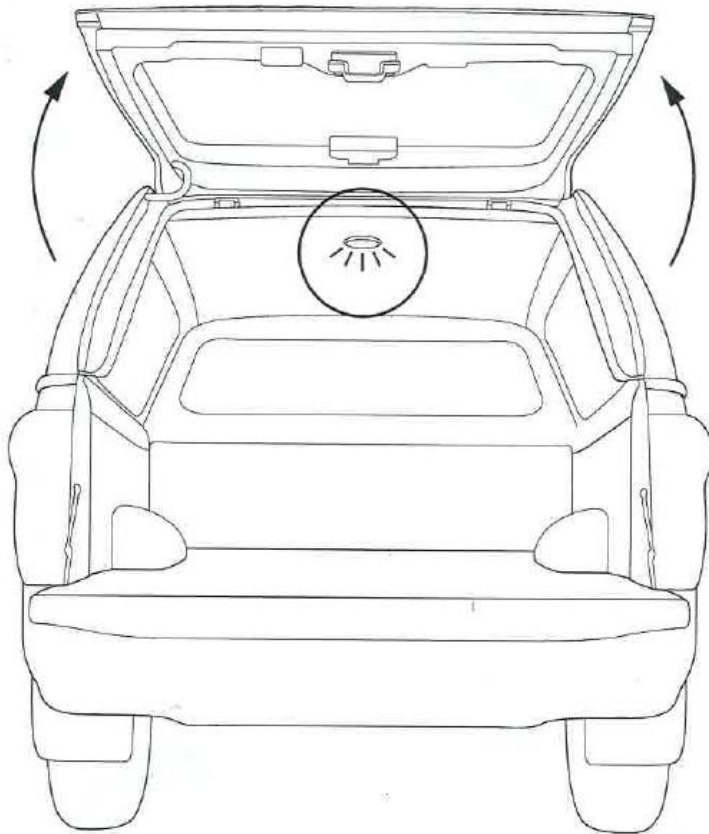

Room Lamp checking by opening the rear door then the Room Lamp will be on.

52

Check the Central Lock / Room Lamp working.

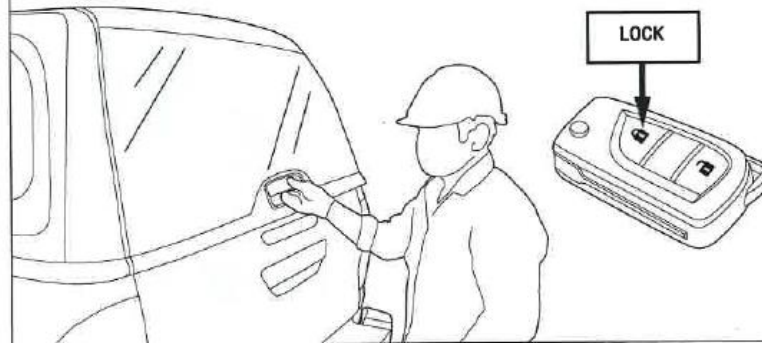

Central Lock checking by pressing the vehicle remote key at the Lock position, Canopy will be lock and cannot open.

53

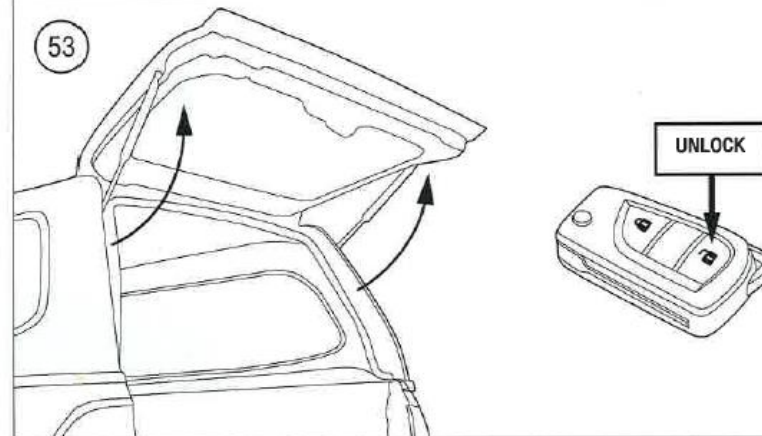

Central Lock checking by pressing the vehicle remote key at the Unlock position, Canopy will be open.